

FEATURES:

- LAN interface suitable for 10/100/1000Base-TX applications
- RJ45/USB stacked design saves on PCB real estate
- USB module complies with USB 2.0 standards and meets CAT5 Fast Ethernet industry performance standard
- Magnetics are 100% electrically tested for HI-POT and continuity
- Meets or exceeds IEEE 802.3 and ANSI X3.263 standards including 350 μ H minimum OCL with 8 mA bias
- Recognized by UL 60950-1



YUAN DEAN SCIENTIFIC



RJ45 Jack 45F SERIES

With Magnetics
Single Port/Dual USB
10/100/1000 Base-Tx
TAB Up
Dual USB Integrated



ELECTRICAL SPECIFICATIONS@25°C

Operating temperature 0°C TO 70°C

Part Number	Data Rate	Turns Ratio		LEDs	Insertion Loss (dB MAX)	Return Loss (dB MIN) 100 Ω ±15 Ω				Crosstalk (dB TYP)			Common Mode Rejection (dB TYP)		Hipot (Vrms) @ 60Hz
		TX	RX	L/R		1-100 MHz	1-30 MHz	30-60 MHz	60-80 MHz	1-10 MHz	32-60 MHz	60-100 MHz	1-50 MHz	50-100 MHz	
45F-10102DYD2NL	10/100	1CT:1	1CT:1CT	G-O/Y	-1.0	-18	-16	-12	-40	-35	-30	-30	-20	1500	
45F-10202GDD2NL	10/100/1000	1CT:1	1CT:1	G/G-O	-1.0	-18	-16	-12	-40	-40	-35	-30	-25	1500	



Mechanical and Dimension

8 PIN (Symmetrical feet)

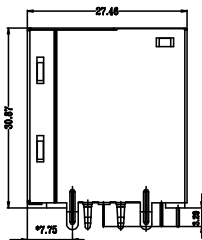
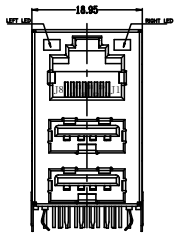
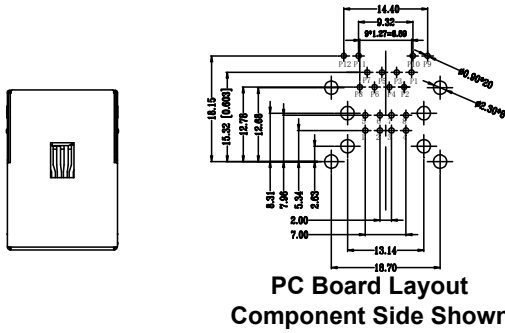

10 PIN (Symmetrical feet)

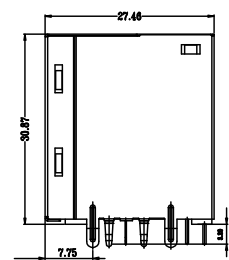
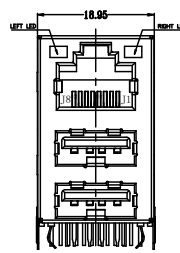
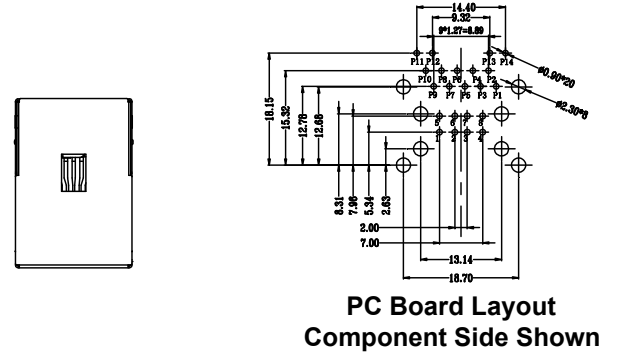

8 PIN (Asymmetric foot)

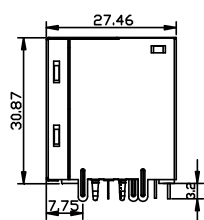
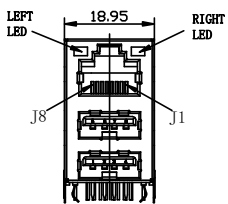
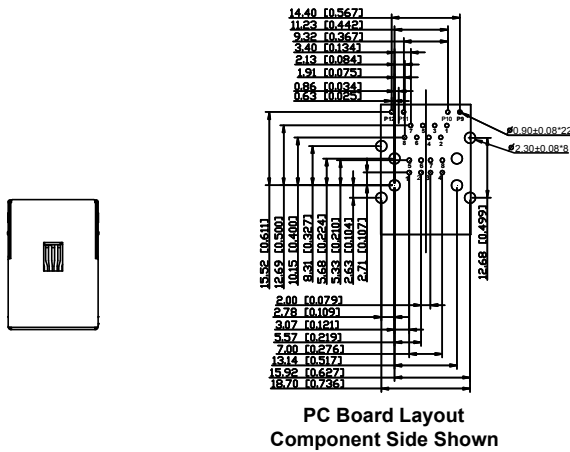

10PIN (Asymmetric foot)

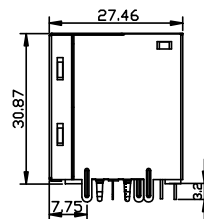
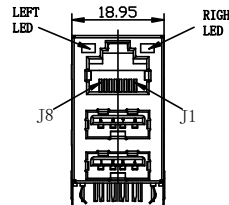
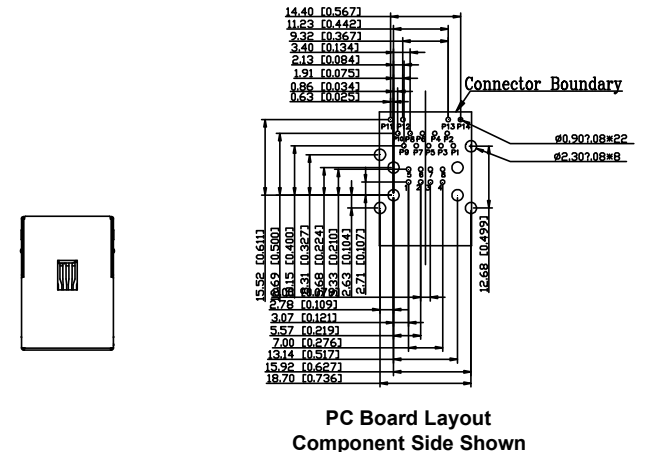

Schematics

45F-10101

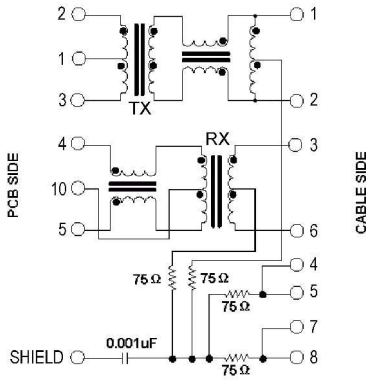

45F-10102

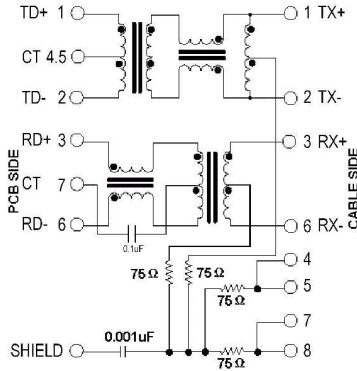

45F-10103

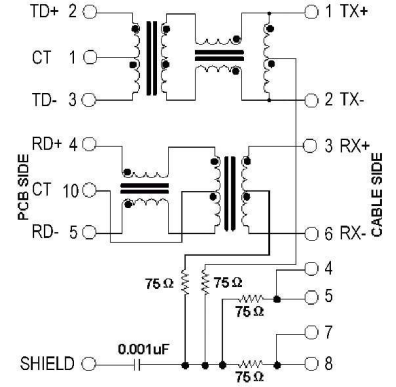

45F-10104

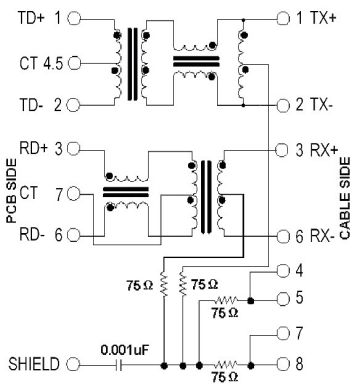

45F-10203

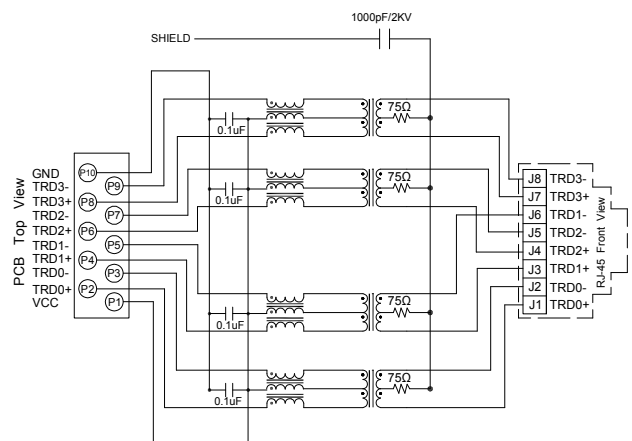

45F-10220

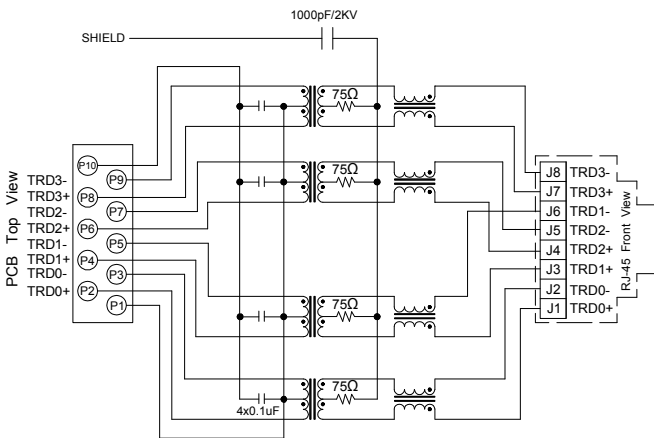

45F-10221

