

FEATURES :

- 14PIN DIL Package
- High Efficiency up to 85%
- Internal SMD Construction
- Unregulated Output Types
- No External Component Required
- Operating Temperature:-40°C TO +85°C
- Industry Standard Pinout

Specifications typical at TA=25°C, nominal input voltage and rated output current unless otherwise specified

| Part Number | Output Voltage | Output Current | Efficiency | Package Style | Recognized By UL 60950-1 |
|---------------|----------------|----------------|------------|---------------|--------------------------|
| | Vdc | mA | %Typ | | |
| 22D-XXS03NNL | 3.3 | 303 | 70 | 1 | |
| 22D-XXS05NNL | 5 | 200 | 70 | 1 | |
| 22D-XXS09NNL | 9 | 112 | 75 | 1 | |
| 22D-XXS12NNL | 12 | 84 | 78 | 1 | |
| 22D-XXS15NNL | 15 | 67 | 80 | 1 | |
| 22D-XXS24NNL | 24 | 42 | 82 | 1 | 22D-05D05NNL |
| 22D-XXD03NNL | ±3.3 | ±150 | 70 | 1 | 22D-05D12NNL |
| 22D-XXD05NNL | ±5 | ±100 | 70 | 1 | 22D-05D15NNL |
| 22D-XXD09NNL | ±9 | ±56 | 75 | 1 | 22D-05D24NNL |
| 22D-XXD12NNL | ±12 | ±42 | 78 | 1 | 22D-12D12NNL |
| 22D-XXD15NNL | ±15 | ±34 | 80 | 1 | 22D-12D15NNL |
| 22D-XXD24NNL | ±24 | ±21 | 82 | 1 | 22D-24D05NNL |
| 22D-XXS05N2NL | 5 | 200 | 70 | 2 | 22D-24D12NNL |
| 22D-XXS09N2NL | 9 | 112 | 75 | 2 | 22D-24D24NNL |
| 22D-XXS12N2NL | 12 | 84 | 78 | 2 | |
| 22D-XXS15N2NL | 15 | 67 | 80 | 2 | |
| 22D-XXS24N2NL | 24 | 42 | 82 | 2 | |
| 22D-XXD05N2NL | ±5 | ±100 | 70 | 2 | |
| 22D-XXD09N2NL | ±9 | ±56 | 75 | 2 | |
| 22D-XXD12N2NL | ±12 | ±42 | 78 | 2 | |
| 22D-XXD15N2NL | ±15 | ±34 | 80 | 2 | |
| 22D-XXD24N2NL | ±24 | ±21 | 82 | 2 | |

Note:

- 1."XX" Is Input Voltage:03 = 3.3Vdc,05=5Vdc,09=9Vdc,12=12Vdc,15=15Vdc.24=24Vdc, 48=48Vdc.
2. Over 48Vdc input voltage, using the 2nd package.
3. The input voltage increases, there will be an increase in efficiency.

Input Specifications

| Parameters | Conditions | Min | Typ | Max | Units |
|-------------------|------------|-----|-----|-----|-------|
| Voltage Tolerance | Vo,Io Nom | | | ±10 | % |
| Filter | Capacitor | | | | |

YUAN DEAN SCIENTIFIC



DC-DC Converter

22D SERIES

1Watt

1KV Isolated

Single & Dual Output

DIL14



Temperature Derating Graph

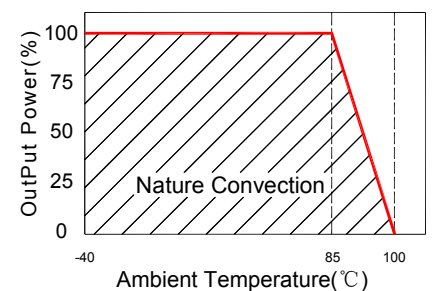

www.yds.com.tw



TEL : 886-6-3842899 FAX : 886-6-3843288
E-MAIL : ydsweb@yds.com.tw

Rev:1 2018/10/08

Output Specifications

| Parameters | Conditions | Min | Typ | Max | Units |
|---------------------------------|--------------------------------------|-----|-----|-----|-------|
| Voltage Tolerance | 100% full load | | | ±5 | % |
| Short Circuit Protection | Short Term | | | 1 | Sec |
| Line Regulation | For 1.0% OF Vin | | 1.2 | | % |
| Load Regulation | 3.3V,5V (10% To 100% F.L.) | | | 15 | % |
| Load Regulation | 9V,12V,15V,24V (10% To 100% F.L.) | | | 10 | % |
| Ripple & Noise | BW=DC To 20MHz | | | 100 | mVp-p |
| Transient response setting time | 50% load step change | | 350 | | us |

General Specifications

| Parameters | Conditions | Min | Typ | Max | Units |
|-----------------------|-----------------------------|---------|------------------|-----|-------|
| Isolation Resistance | 500Vdc | 1000 | | | MΩ |
| Switching Frequency | Full load, nominal input | | 100 | | KHz |
| Operating Temperature | | -40 | | +85 | °C |
| Humidity | Non Condensing | | | 95 | % |
| Cooling | Free air Convection | | | | |
| Case material | DAP | | | | |
| MTBF | MIL-HDBK-217F @25°C | 3500000 | | | Hours |
| Weight | Package 1 or Package 2 | | 2.3 or 2.8 | | g |
| Dimensions | Package 1 | | 20.32x10.16x6.80 | | mm |
| Dimensions | Package 2 | | 20.32x10.16x7.70 | | mm |

Markings and dimensions

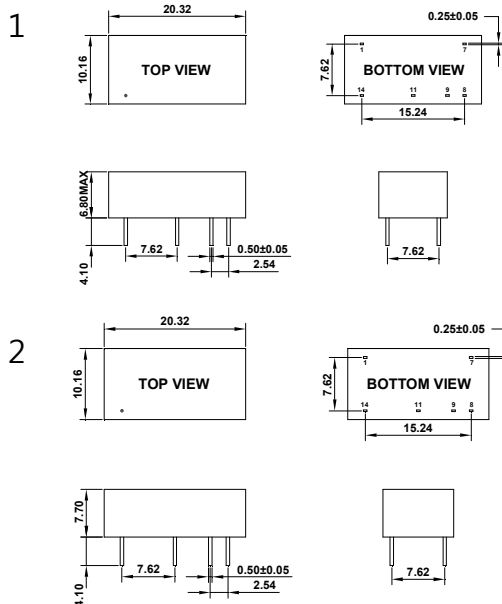

Unit : mm Unless otherwise specified, all tolerances are ±0.25

Tolerance Envelope Graph

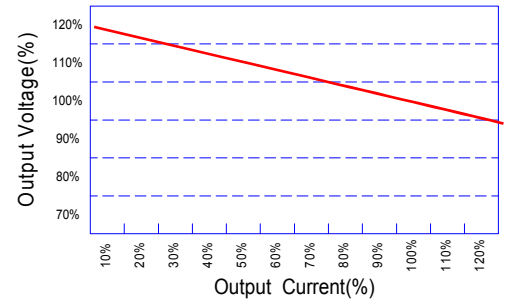

Part Number

22D - 05 D 05 N 2 NL
A B C D E F G

- A:Series
- B:Input Voltage
- C:Single(S)Dual(D)
- D:Output Voltage
- E:Unregulated(N)
- F:Package
- G:RoHS Version

Recommended Test Circuit

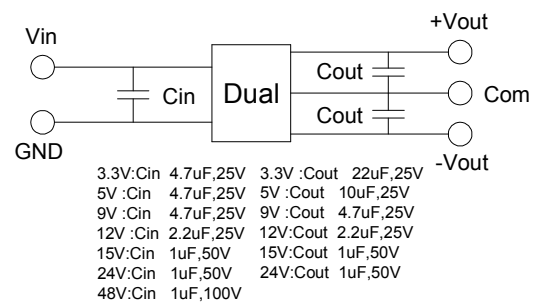
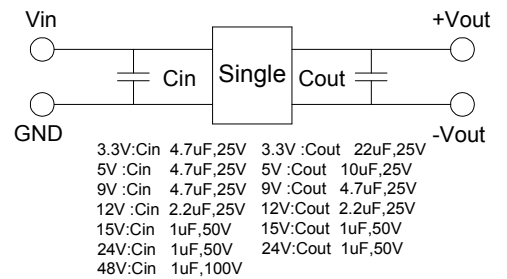

PIN Connection

| PIN | 1 | 7 | 8 | 9 | 11 | 14 |
|--------|------|----|-------|-------|-------|------|
| Single | -Vin | NC | -Vout | +Vout | NC | +Vin |
| Dual | -Vin | NC | COM | +Vout | -Vout | +Vin |

